



# Axelent Impact protection

---

Version  
1.0  
English Ltd



# A new way of preventing damage in industrial environments

How often have you experienced the following? A forklift goes astray and is stopped by a steel bollard, safety rail or bracket. Unfortunately, the collision damages the steel bollard. As well as the concrete floor, the forklift and the goods. Moreover, the operator is injured.

Surely things don't have to be like this?

Imagine if you could replace those heavy-duty collision guards with a set of solutions designed to absorb impacts and avert collisions while also reducing your maintenance costs?

Well, these solutions already exist. And they're available at Axelent.

## Axelent Group

The Axelent Group has grown into an international group of companies with a total workforce of over 200 people. Our products are sold in 60 countries and our vision is to keep on expanding.



Axelent Group consists of four companies; Axelent, Axelent Engineering, Axelent Software and Axelent Safe-X. The four companies have a joint vision of making industry competitive and profitable through automation, safety, rational procedures, functions and expertise. All companies are in the growth stage, developing their businesses on both the Swedish and international markets.



### AXELENT AB

Axelent AB, a leading manufacturer and global supplier of mesh panel systems for machine guarding and partitioning within industry, warehousing and lost prevention. The head office is located in Hillerstorp, Sweden, along with research and development, production, storage and packaging. Axelent has sales offices in 60 countries and subsidiaries in more than 10 countries.

[www.axelent.com](http://www.axelent.com)



### AXELENT ENGINEERING

Axelent Engineering AB provides services and products within automation predominantly to producing industry in Scandinavia. The core business is custom hardware and robotic solutions with an emphasis on profitable flow for the entire lifecycle. By partnering with Dassault Systèmes, a world leader in 3D and PLM (Product Lifecycle Management) solutions we can also offer PLM services and products such as CATIA, 3DVIA, DELMIA and ENOVIA. This combination makes Axelent Engineering an even more complete partner for the industry in terms of innovative and profitable flows.

[www.axelentengineering.com](http://www.axelentengineering.com)



### AXELENT SOFTWARE

Axelent Software develops and markets user licences for their in-house software applications SnapperWorks and SafetyWorks. The programs are based on distributed platforms and standards that ensure a long length of life, continuous development and easy connectivity to other systems. Axelent Software's products are based on simplicity and ease of use and is in its original version developed for Axelent's products, but through various customizations applicable in most industries with standardized products.

[www.axelentsoftware.com](http://www.axelentsoftware.com)



### AXELENT SAFE-X

Axelent Safe-X offers a range of products for construction, outdoor environments, industry, warehouse and workplace. Examples of products are store room walls, bicycle racks, paper baskets, ramps, mesh shelves and impact protection. Axelent Safe-X products can be found under Axelent's X-Tra range, including products from well-known brands.

[www.axelentsafex.se](http://www.axelentsafex.se)



# FlexCore® Bollard

Surface-Mounted, Shock-Absorbing Bollard

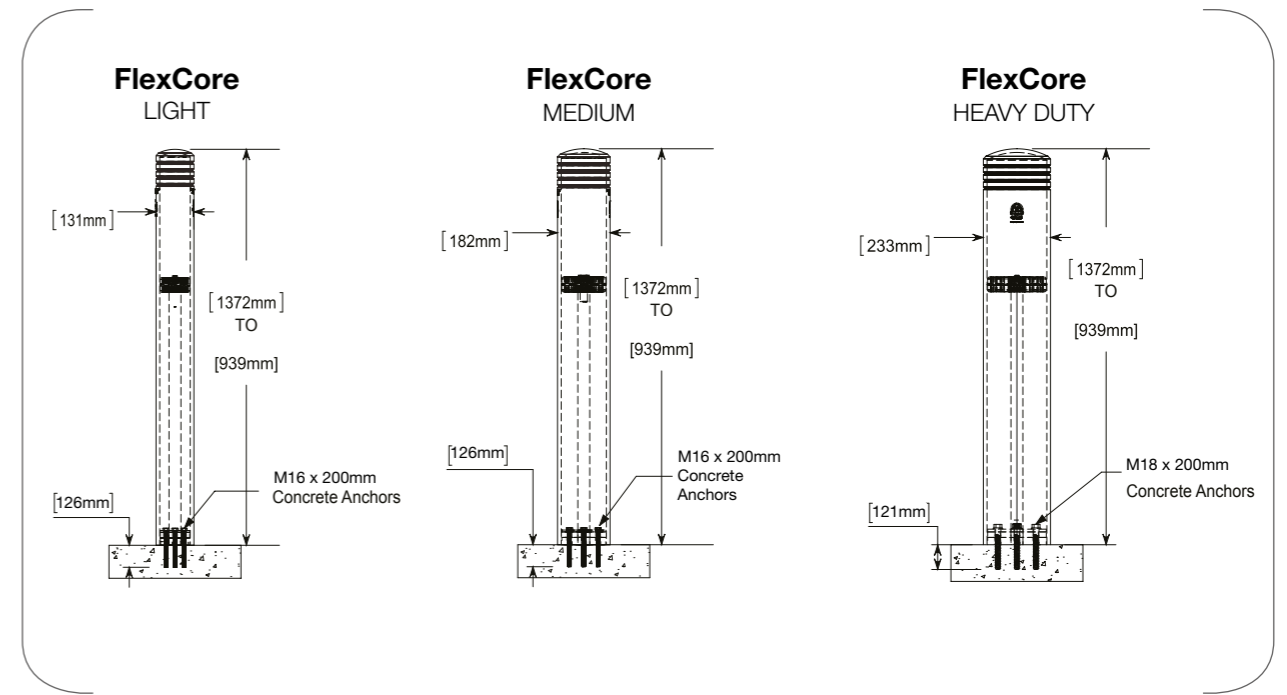

4 layers of impact energy absorption for superior performance

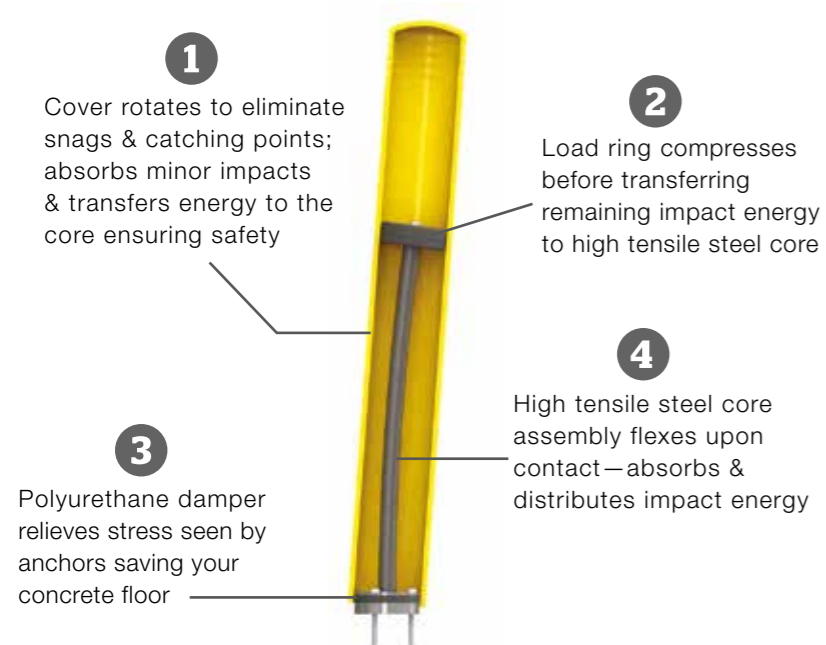

Shock-absorbing design—no dents, no need to repaint.

## FlexCore Light Bollard

M011-137-013

Materials: 131mm diameter HDPE shell, steel core, anchor kit

## FlexCore Medium Bollard

M011-137-018

Materials: 182mm diameter HDPE shell, steel core, anchor kit

## FlexCore Heavy duty Bollard

M011-137-023

Materials: 233mm diameter HDPE shell, steel core, anchor kit

## Colours

Yellow  
RAL 1033



U.S. Patent Number:  
7901156

# Deflector Post

Floor-Mounted, Impact Deflecting Post

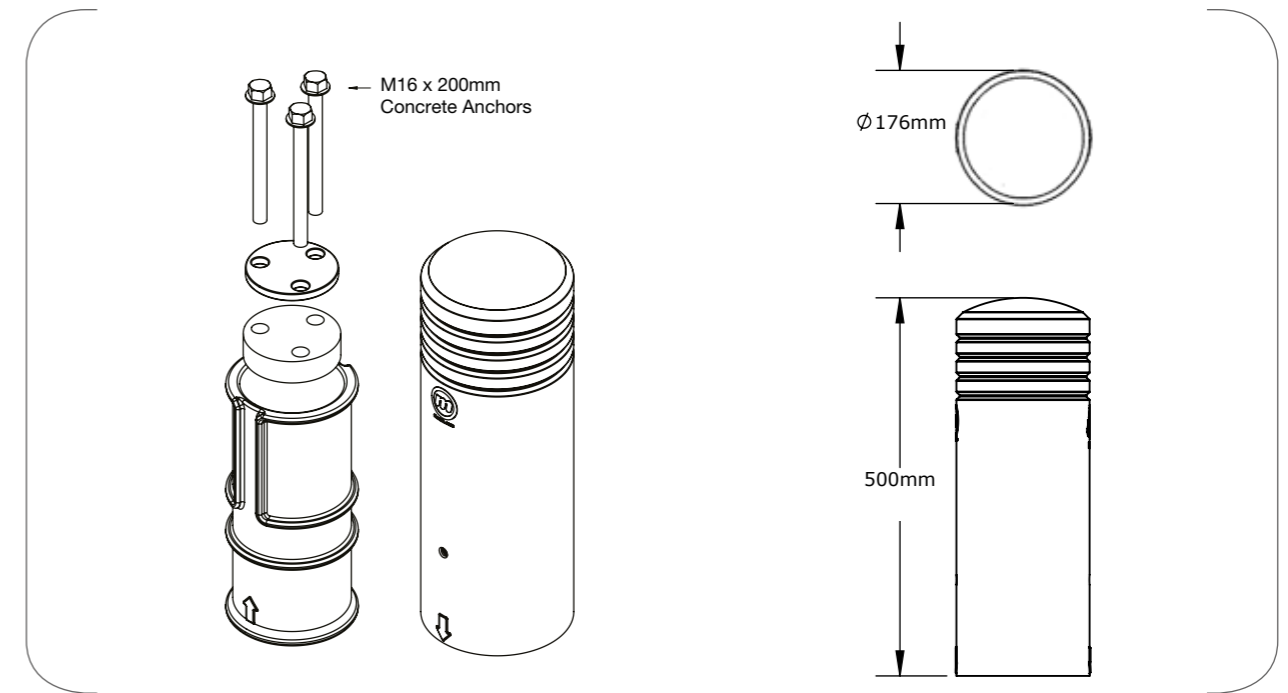

## Rotating design deflects damage in high traffic environments

Rotating HDPE shell with nylon bearings spins & rolls when impacted

Ductile Iron & rubber core absorbs direct impacts, preventing damage to your floor and equipment

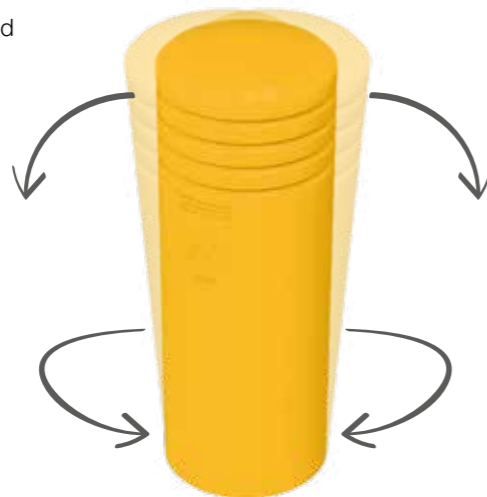

Domed shell provides a sanitary top eliminating dust & bacteria collecting areas

Engineered to install fast & requires no maintenance, keeping your facility safe

### Deflector Post

M011-050-018

Materials: HDPE shell, iron core, rubber damper, anchor kit

### Colours

Yellow  
RAL 1033



Guides your equipment around high traffic corners to avoid damage.

# Goal Post

Door Frame Protection

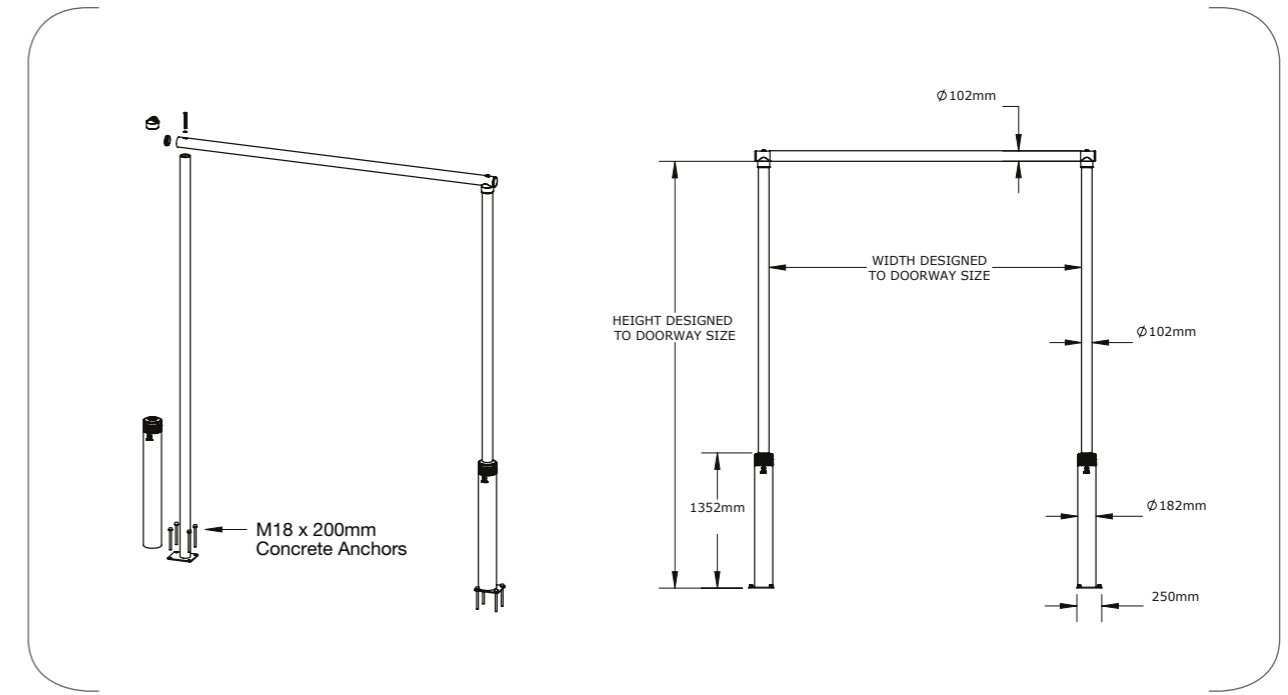

The only goal post system with a replaceable crossbar

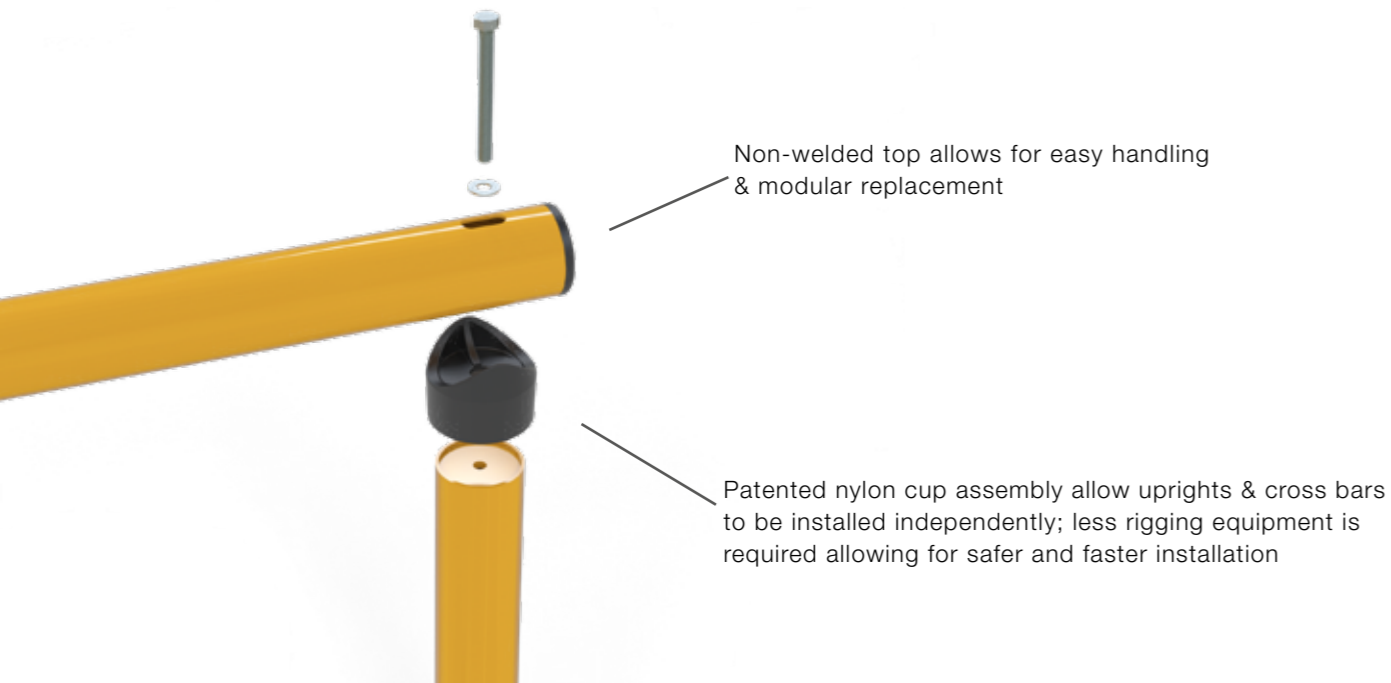

U.S. Patent Number:  
9103163

## Goal Post Kits

Materials: HDPE shells, HDPE sleeves, steel tubing, nylon cups, anchor kit  
How to order: Sizes vary. Width ranging from 2.4 m to 4.9 and heights ranging from 2.4 m to 4.9 m.

## Colours

Yellow  
RAL 1033

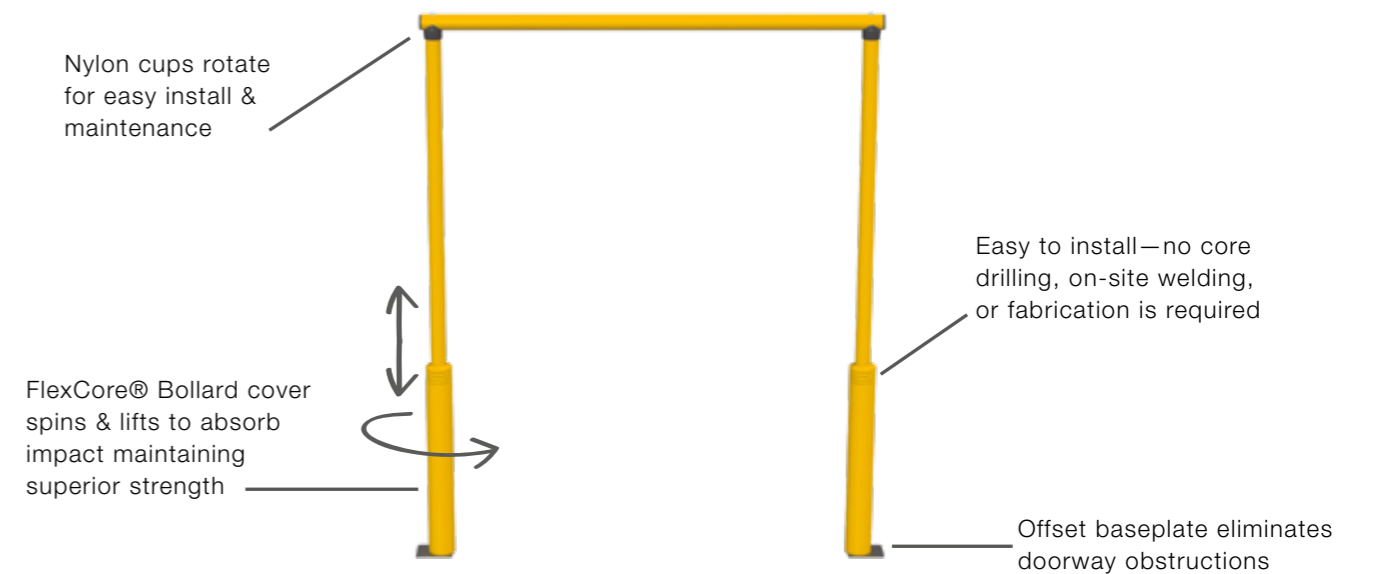



# Pedestrian Barrier System

Pedestrian Safety Railing

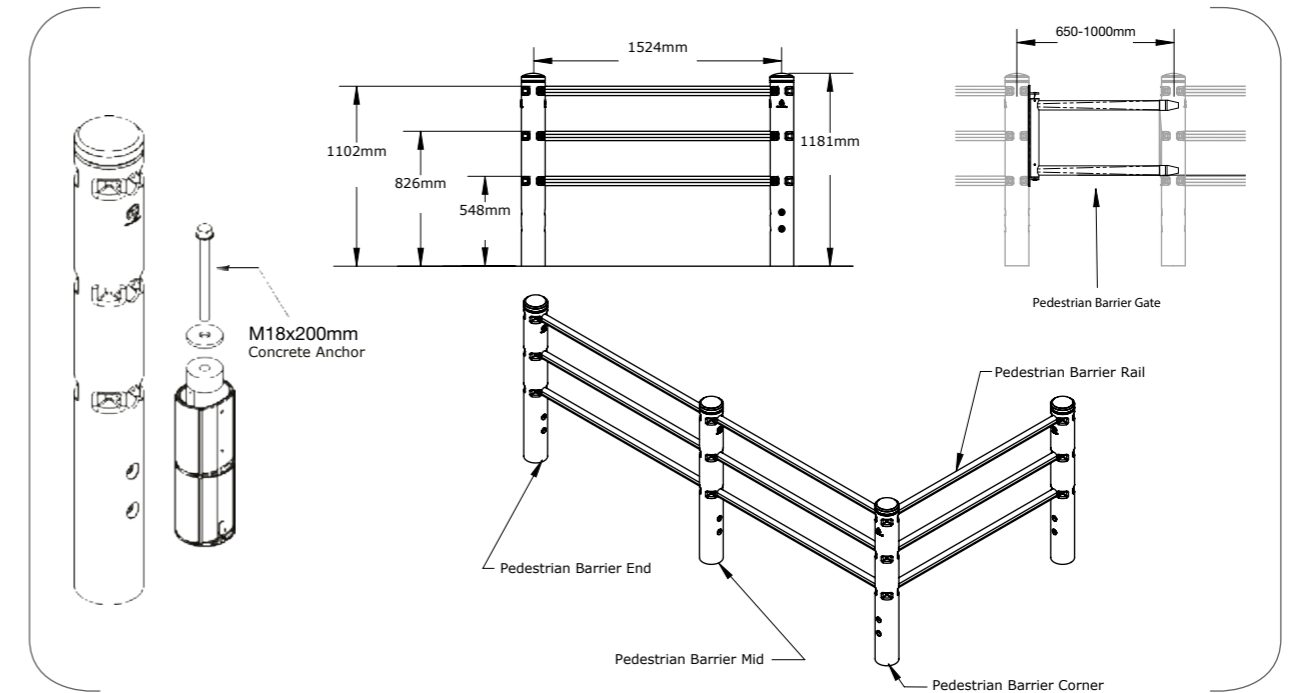

## Shock-absorbing, modular barrier system, protects your people and facility

Shock-diffusing posts

Internal hardware eliminates catching & tripping points maintaining a seamless finish

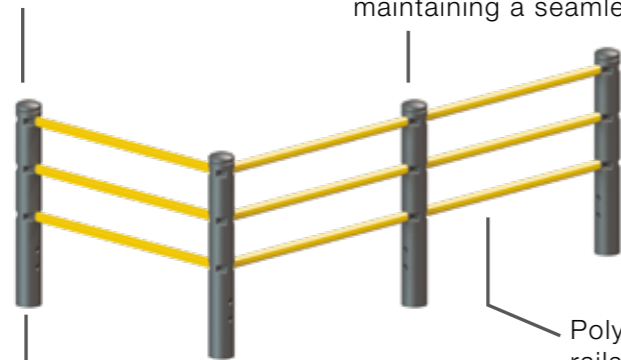

Ductile Iron core is paired with an industrial rubber damper that provides a shock-diffusing rigidity

Polyolefin rails absorb impact energy

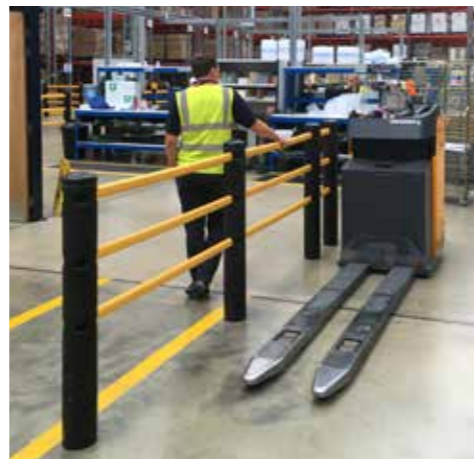

Conforms to OSHA Standard 1910.23 for guarding floor and wall openings with railing and to IBC Standard 1012 regarding handrails, including section 1012.3 concerning the ability to grasp handrails.

### Pedestrian Posts

- M033-118-014E (End)
- M033-118-014M (Middle)
- M033-118-014C (Corner)

Materials: HDPE shell Post, Ductile Iron core, rubber damper, anchor kit

### Pedestrian Rail

M021-000-150

Material: Polyolefin, 1.5 m length

### Pedestrian Barrier Gate

M033-041-100RL

Materials: Polypropylene rails, nylon cam, steel hinge & latch. Mounting hardware included. Post not included.

### Colours

- Yellow RAL 1033
- Black RAL 9004

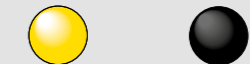

Patent Pending

# Pedestrian Barrier System with Crash Barrier

Pedestrian Safety Railing With Floor-Mounted Barrier System

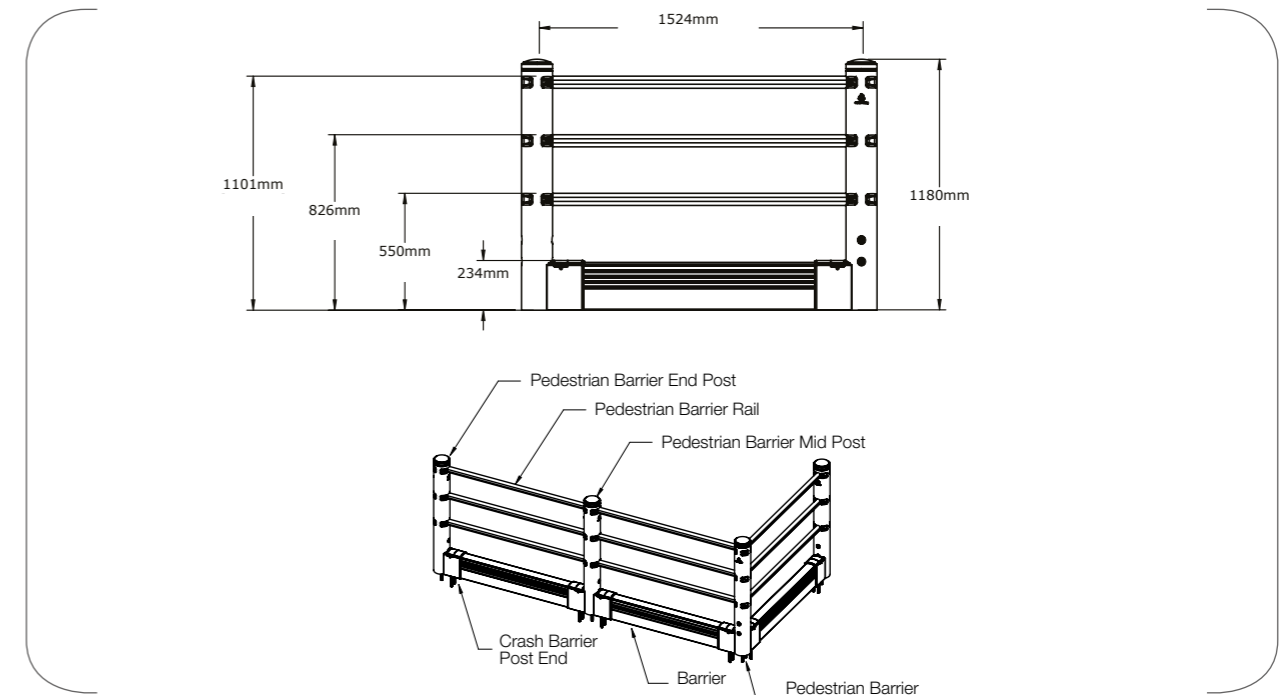

## Pedestrian Barrier integrated with Crash Barrier System to provide an extra level of protection

Provides uncoupled installation so the Crash Barrier can be added to any Pedestrian Barrier run, allowing flexibility in designing your space

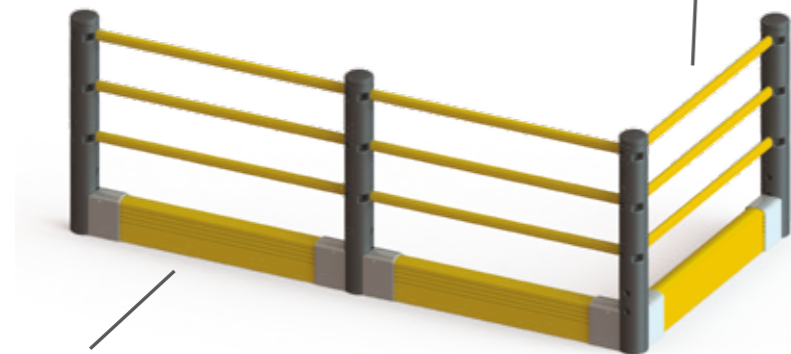

Increases employee safety by providing protection from low forks & pallets

Patent Pending

### Crash Barrier Post End

M046-000-000F

Materials: Ductile Iron post end & cap, rubber damper, anchor kit

### Barrier

M021-023-300

Material: Polyolefin  
Cut to length per 1.5 m assembly



Our fully modular system can incorporate Crash Barrier or a gate to help keep employees safe.

### Colours

Yellow  
RAL 1033



Black  
RAL 9004





# FlexCore GuardRail

Guardrail Safety Barrier

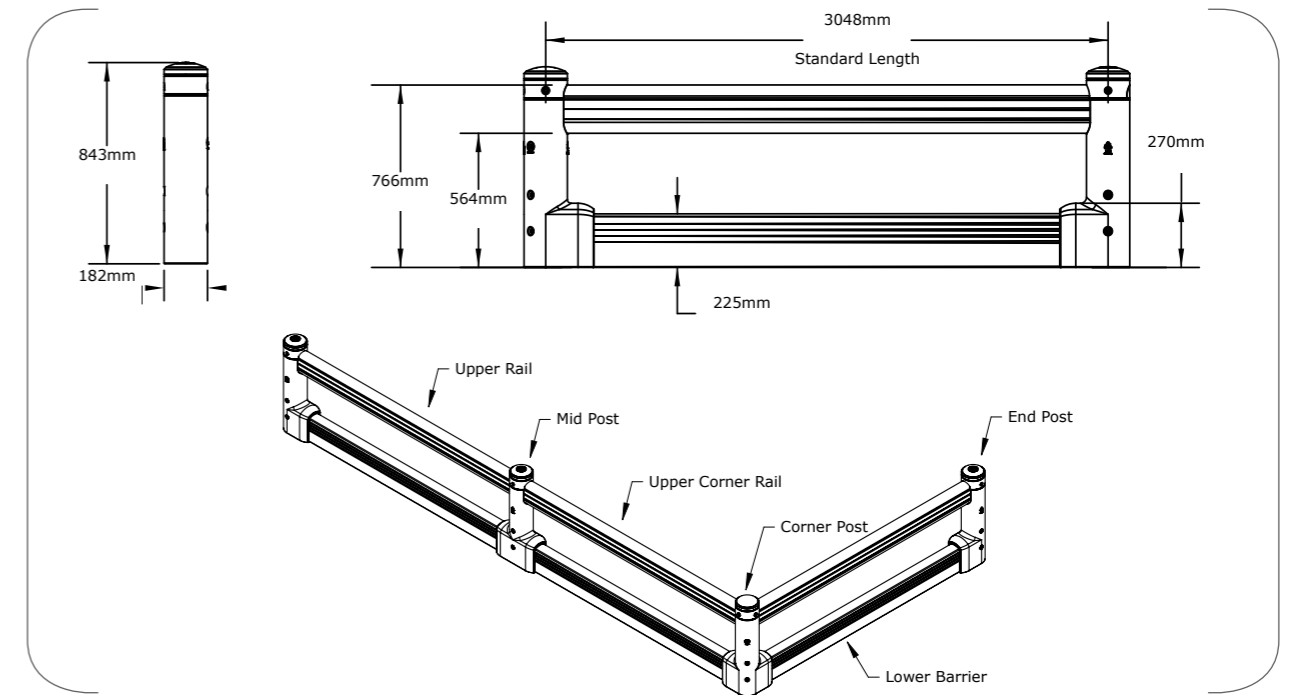
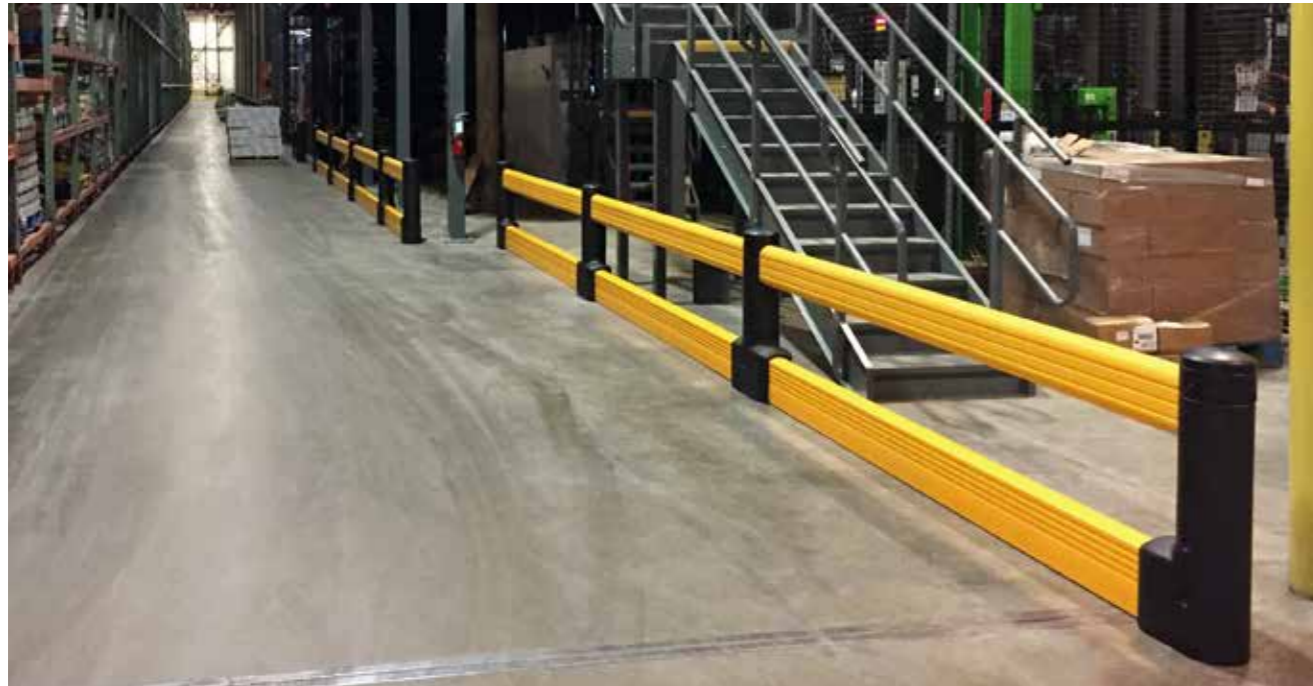

## A flexible guardrail system with impact-absorbing uprights

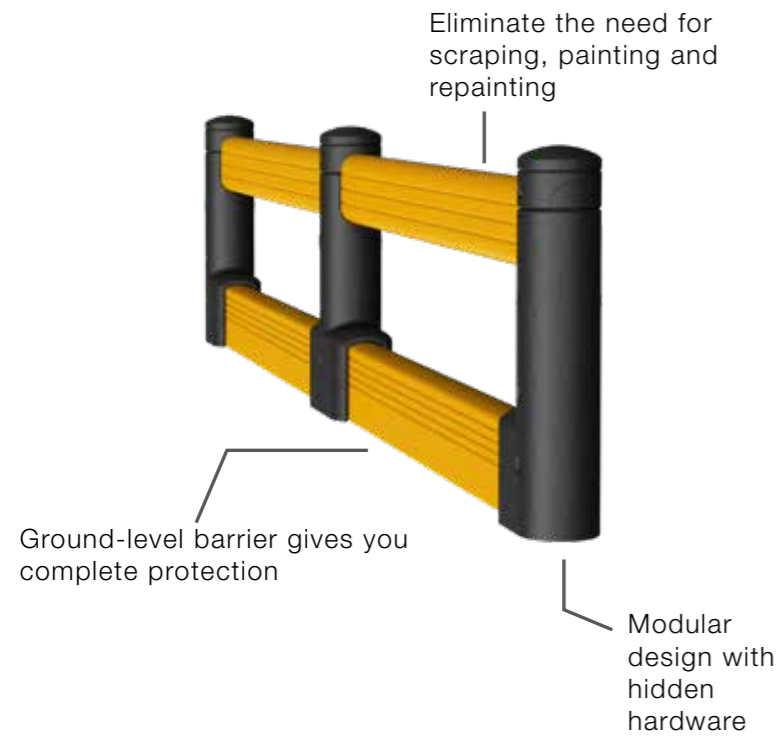

Our easily installed barrier system is designed for areas that need an extra level of protection

Patent Pending

### End Post

M033-084-018E  
Hardware included

### 3 m Upper Rail

M021-023-300T  
Material: Polyolefin Copolymer

### Mid Post

M033-084-018M  
Hardware included

### 3 m Lower Barrier

M021-023-300B  
Material: Polyolefin Copolymer

### Colours

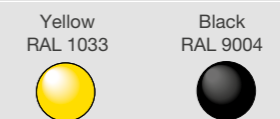



# Crash Barrier System

Floor-Mounted Barrier System

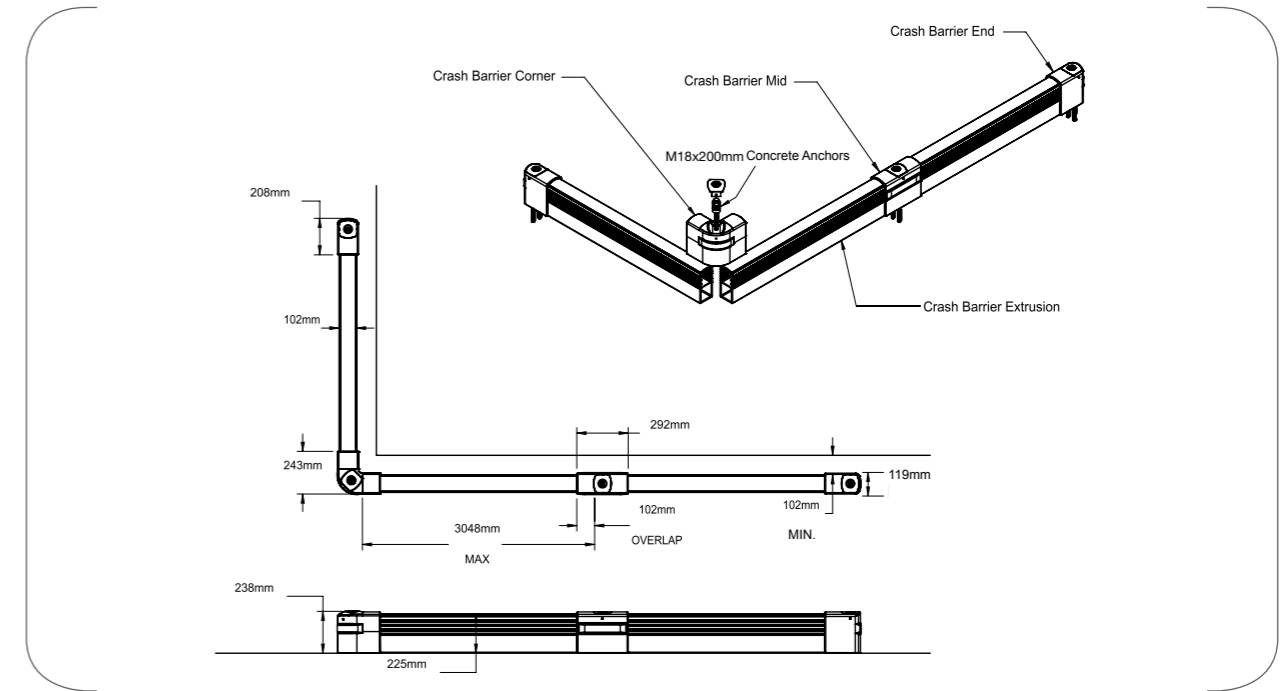

**No more angle iron!**  
Protect your perimeter, racks, columns and define spaces safely

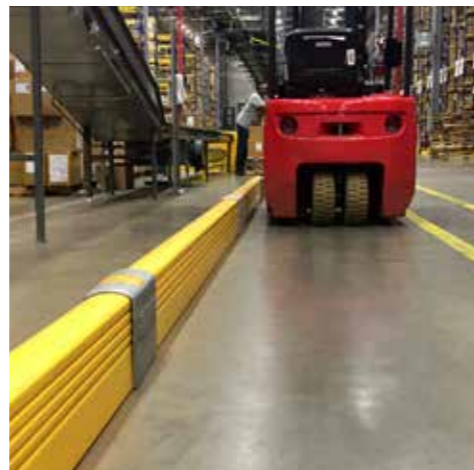
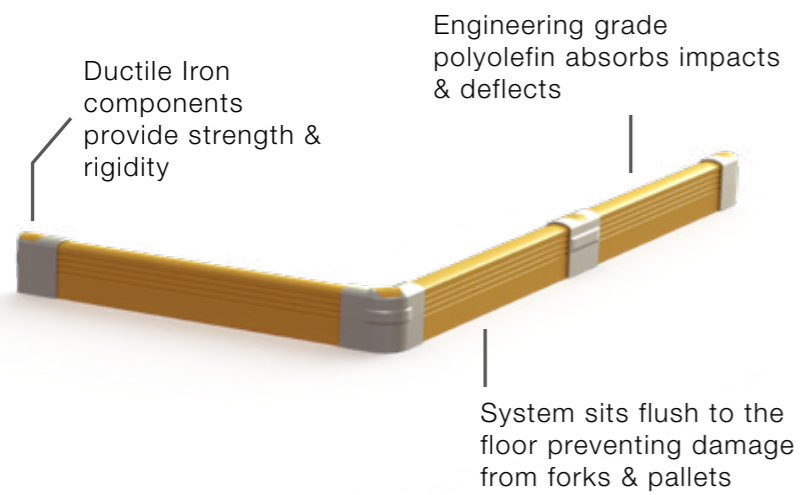

No need to repaint, the outer shell color is consistent throughout. Horizontal ribs mask abrasions.

## Crash Barrier End

- M046-000-000E (End)
- M046-000-000M (Middle)
- M046-000-000C (Corner)

Materials: Ductile Iron, rubber damper, anchor kit

## Barrier

M021-023-300

Material: Polyolefin 3 m length

## Colours

Yellow  
RAL 1033



Patent Pending

# Rack End Protector

High Visibility Rack End Protection

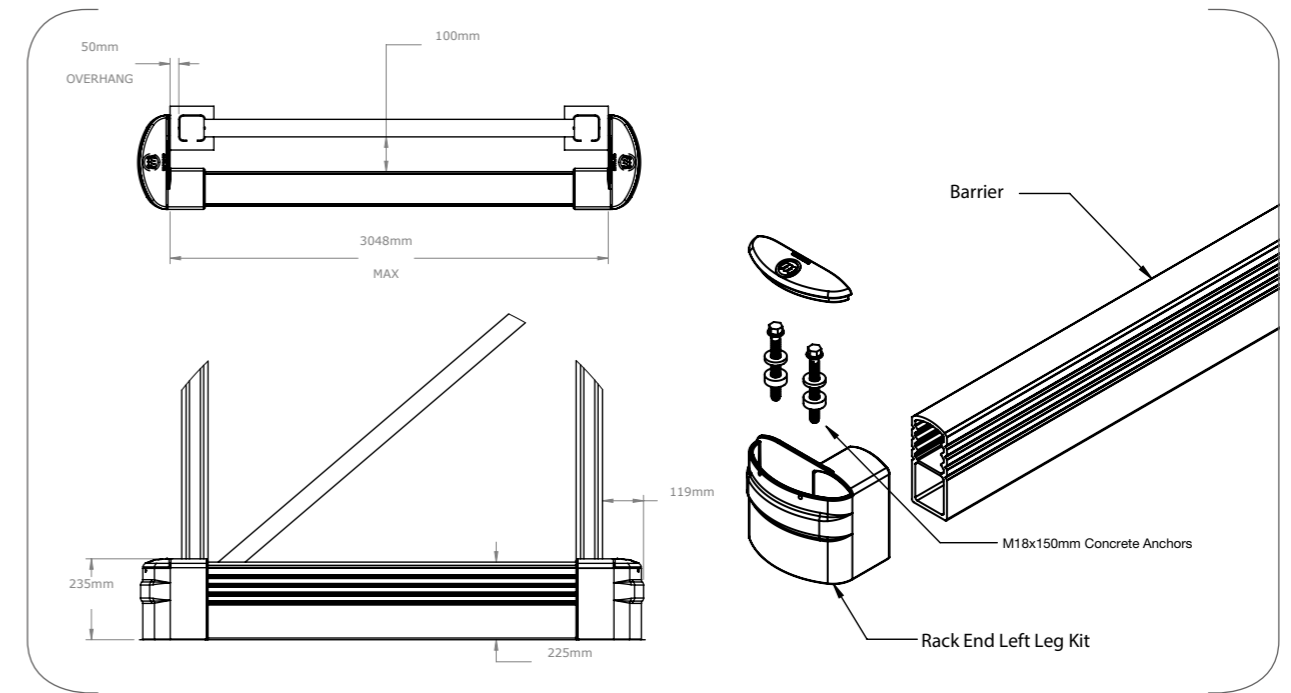

**Absorbs impacts in the middle . . . Deflects impacts on the ends**

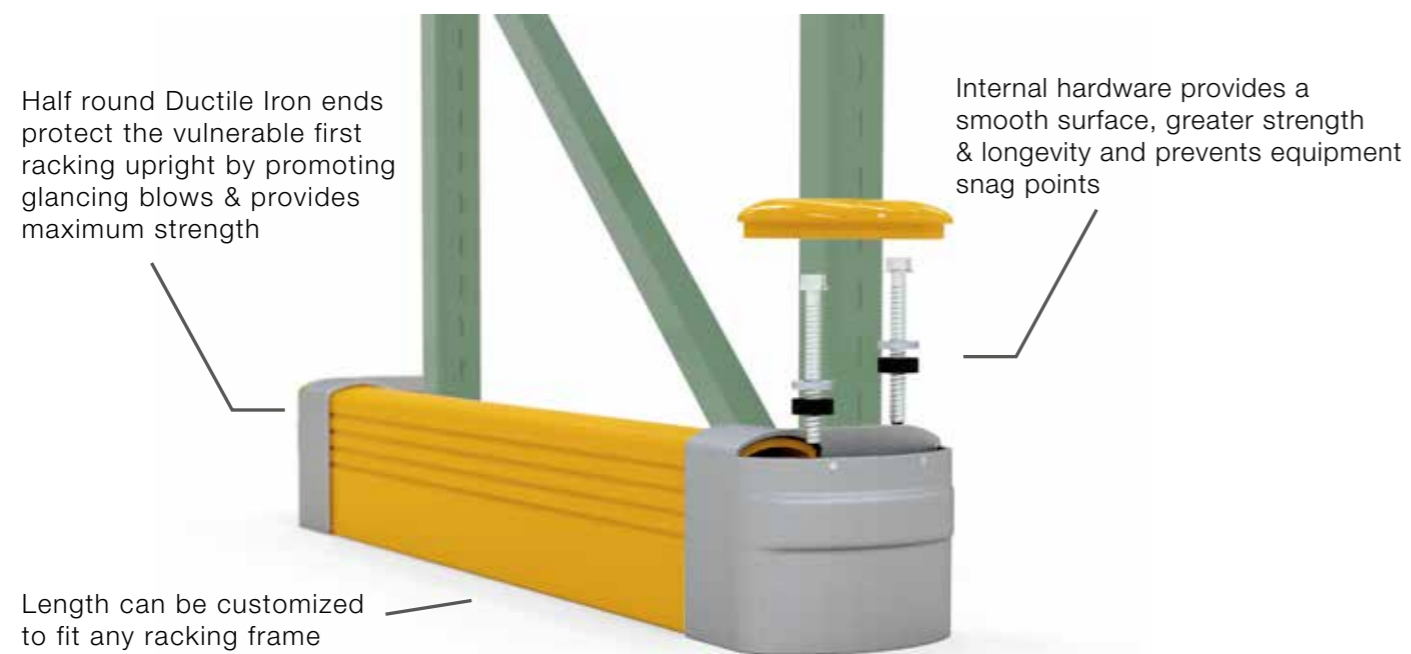

Patent Pending

## Rack End Left Leg

M046-000-000L (Left)  
M046-000-000R (Right)

Materials: Ductile Iron leg & cap,  
Rack End, rubber damper, anchor kit

## Barrier

M021-023-300

Material: Polyolefin, 3 m length

## Colours

Yellow  
RAL 1033



Shock absorbing barrier absorbs impacts perpendicular to the rack end.



# Rack Mounted Guard

Strap-On Impact Protection for Racking

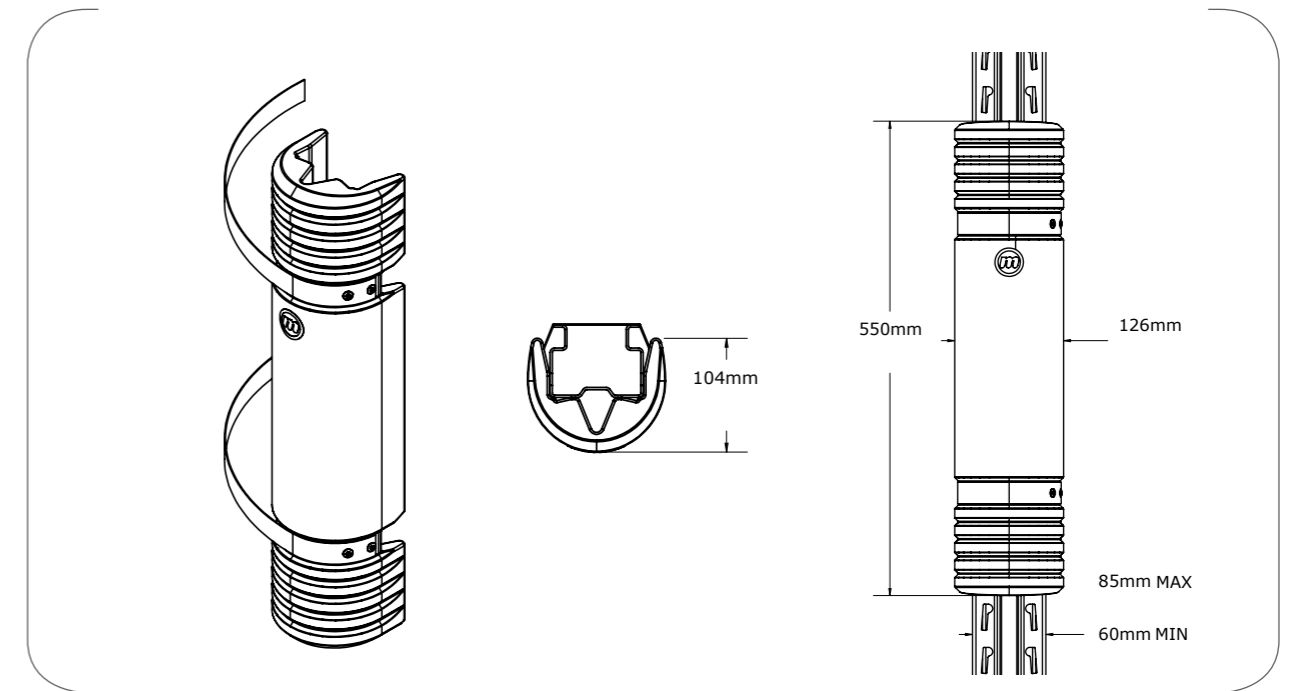

## Flexible solution to protect your racking and its contents

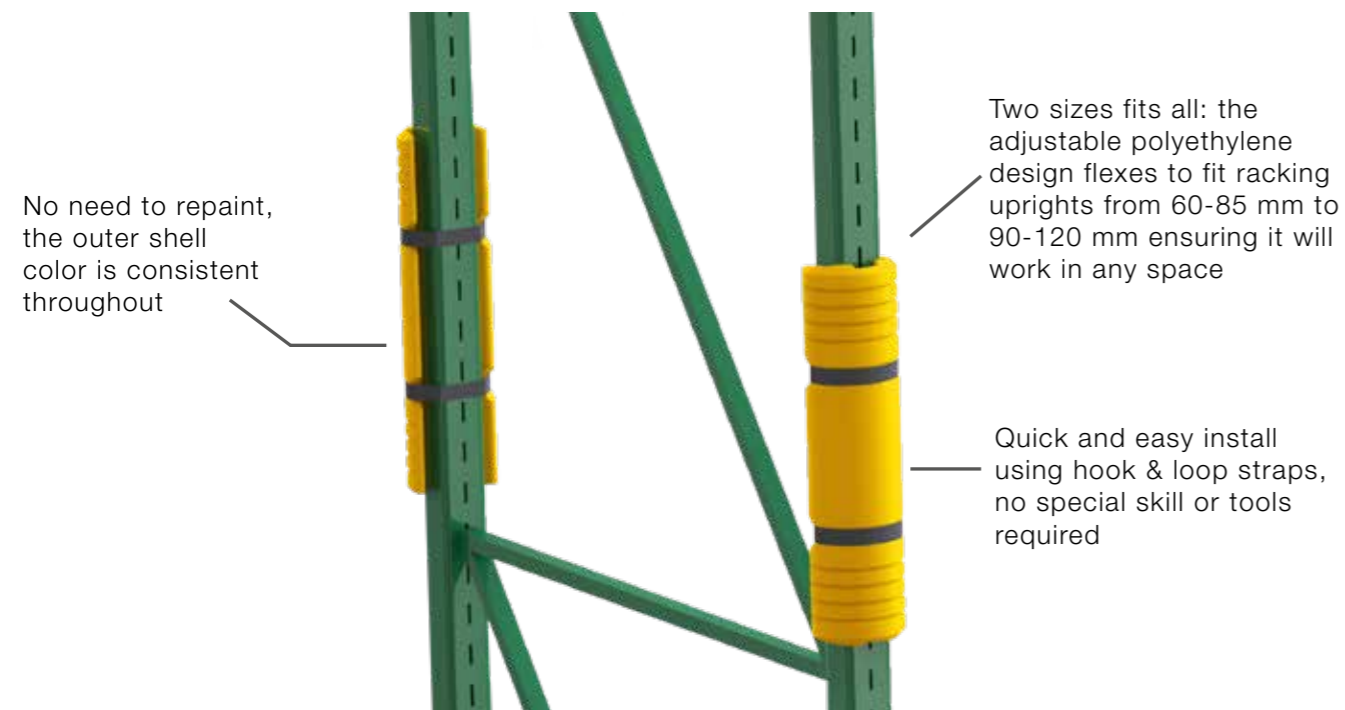

Patent Pending

### Rack Mounted Guard Kit

M081-055-010 (60-85 mm)  
M081-055-012 (90-120 mm)

Materials: Polyethylene body, hook & loop straps

### Colours

Yellow  
RAL 1033



Rack Mounted Guard exceeded impact requirements of EN 15512.

# Shock-Absorbing Rack Guard

Pallet Rack Upright Protection



**Heavy duty performance: Absorbs the impact energy so your racks and concrete don't**

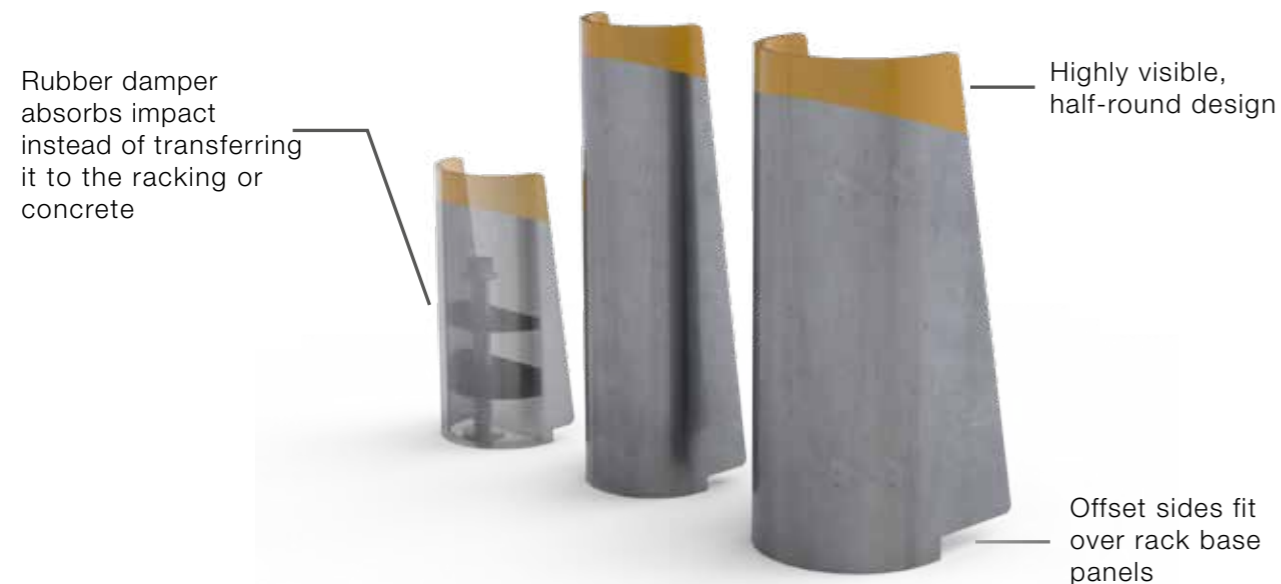

U.S. Patent Number:  
8915670

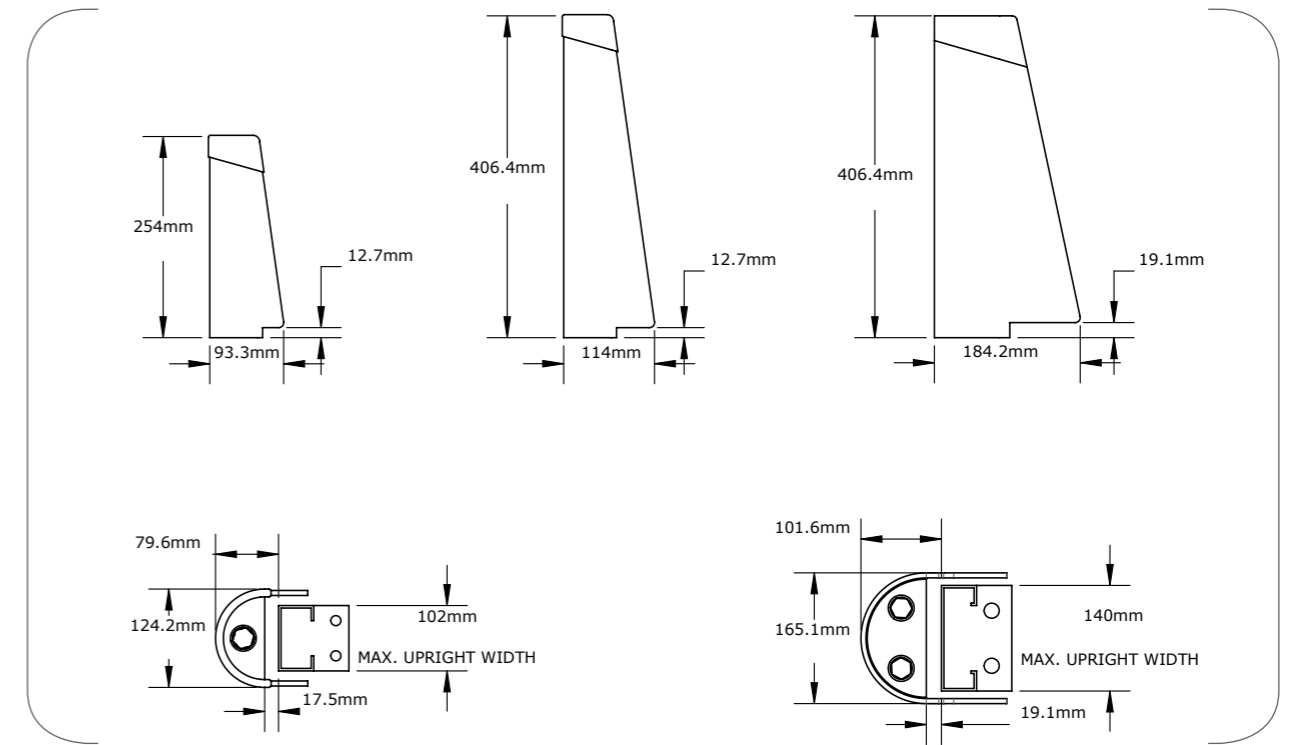

## 250 mm Rack Guard

M086-025-012

Materials: Zinc plated steel  
Shock-Absorbing Rack Guard,  
rubber damper, anchor kit

## 400 mm Rack Guard

M086-040-012

Materials: Zinc plated steel  
Shock-Absorbing Rack Guard,  
rubber damper, anchor kit

## 400 mm Rack Guard XL

For racks wider than 100 mm

M086-040-015

Materials: Zinc plated steel  
Shock-Absorbing Rack Guard,  
rubber damper, anchor kit

## Colours

Yellow  
RAL 1033



Zinc finish will not scratch off or rust leaving it looking like new.



# Column Guard

Adjustable Column Barrier

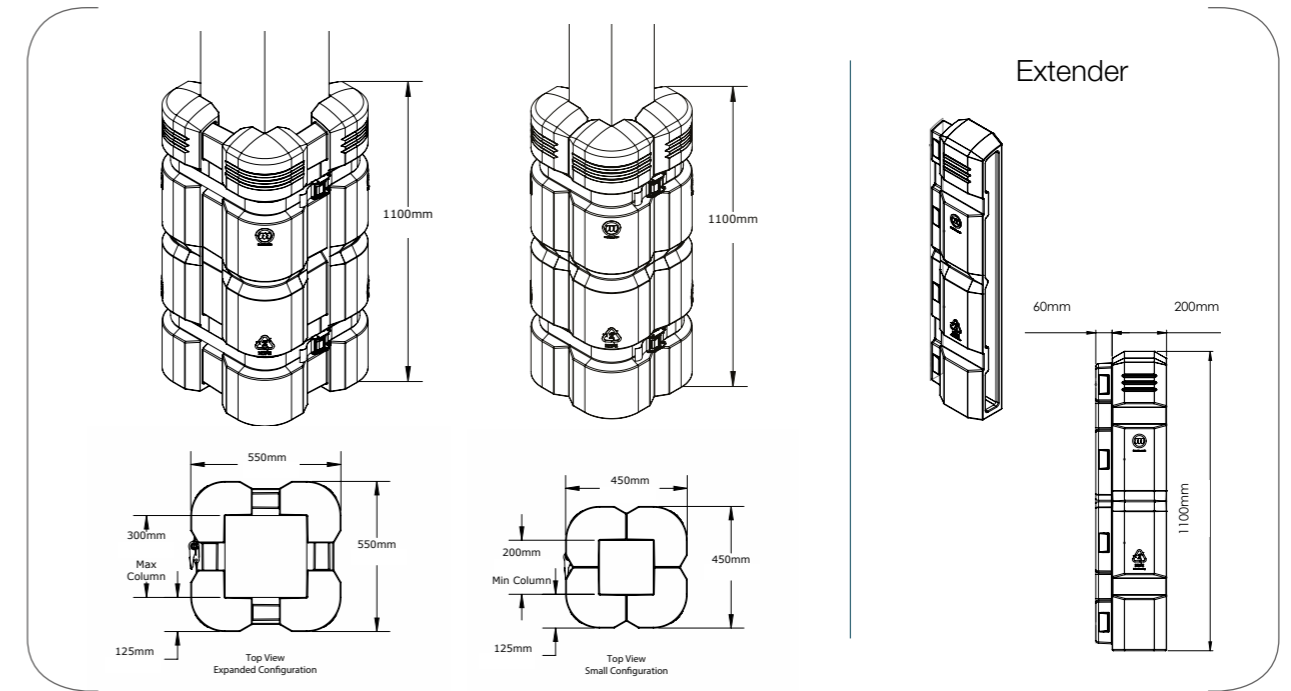

## Expandable assembly protects columns of different sizes from 200 mm to 300 mm

Interlocking design provides superior impact resistance with 4 polyethylene walls vs. the conventional 2 walls for maximum strength

Easy to install straps—no special skill or tools required



Patent Pending

### Column Guard

M071-110-030

Materials: HDPE shell Column Guard, 2 straps

### Colours

Yellow  
RAL 1033



Shock-absorbing assembly installs securely, cushions columns, equipment & drivers during impacts.

### Extender

M071-110-020 (200mm)

Materials: HDPE shell Extending Piece

Foam Spacers available.



To accommodate over-sized columns, we have extenders and foam spacers available.



## Greater Safety Through Better Protection

A full range of engineered solutions that protect your people as well as your property and equipment. Self-protecting products with shock displacement and deflection designed to convert accidents into incidents.

### Safety Blueprint

A solution for every corner of your facility: Let us work with you to develop a comprehensive damage prevention blueprint.

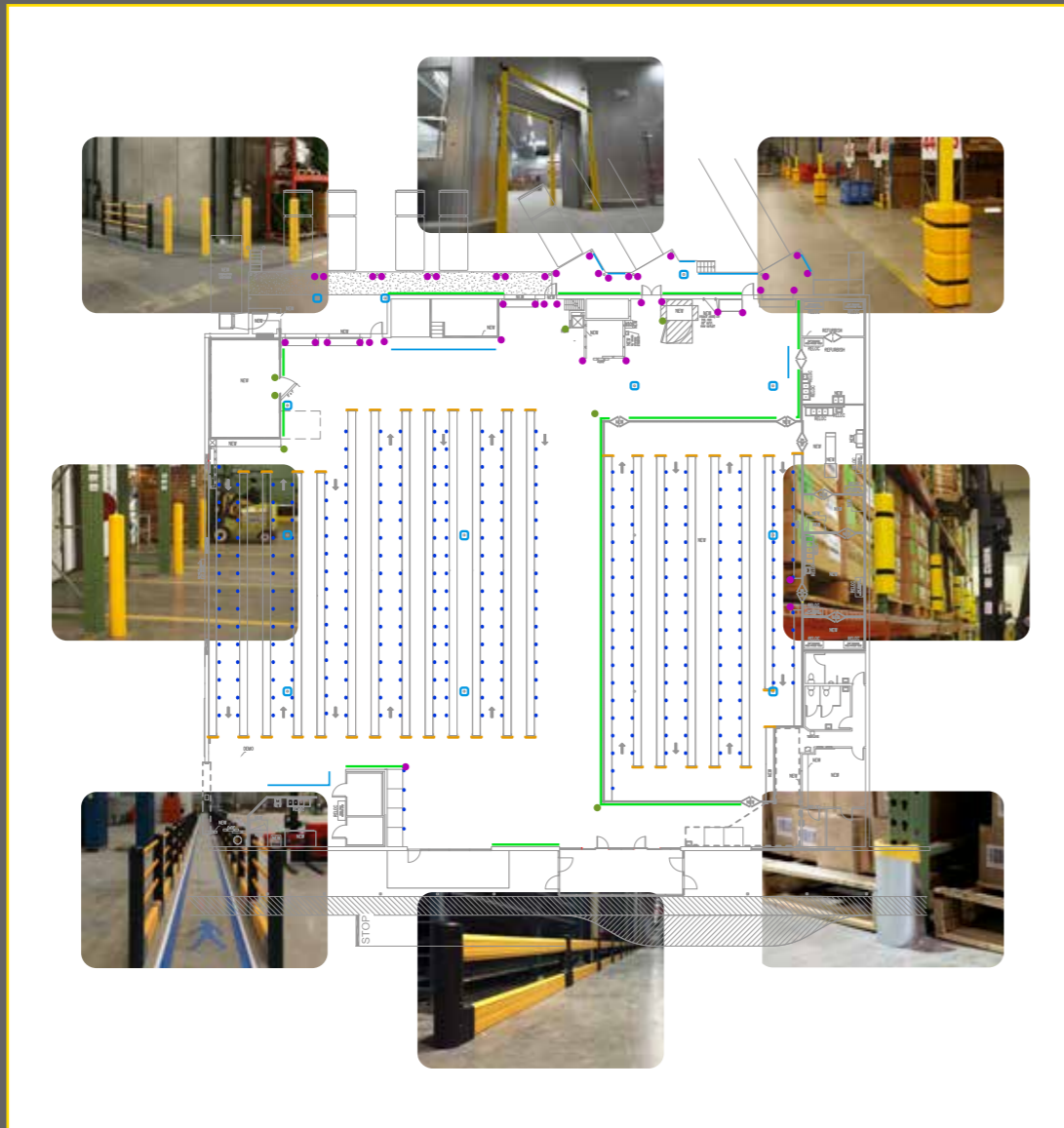

## Preventing Damage Everywhere







AXELEN'T LTD · UNIT 9 HILLMEAD INDUSTRIAL ESTATE · MARSHALL ROAD  
SWINDON · SN5 5FZ  
TEL: 01793 523535 · FAX: 01793 432424  
SALES@AXELEN'T.COM · WWW.AXELEN'T.COM

